



Midas has been designing and manufacturing live performance mixing consoles for the world's most demanding sound engineers, performers and production rental companies since the early 1970s.

The evolution of Midas consoles throughout the 30-year history of this classic marque has always paralleled, and often led, increasingly sophisticated audio innovations for the world-wide entertainment technology industry. Raising the standards of sonic quality through continual research and development has always been - and still remains - our overall aim.

Equally important to us is the design and implementation of many new areas of control functionality and user-friendly desk operation to anticipate and accommodate the rapidly changing and expanding needs of audio professionals who specify Midas consoles for their major tours, festivals, international events, broadcast projects and prestigious fixed installations.

The Midas design pedigree has, since our birth, been founded upon a track record of achieving a unique symbiosis with working sound engineers around the planet - engineers who respect and endorse our proven technology in the light of their responsibilities to their internationally-based clients who are themselves the leading lights of our industry.

designed and printed in england by **Veldonn Printers Limited** tel: +44 1562 66477 fax: +44 1562 829026 email: sales@veldonn.co.uk web: www.veldonn.co.uk

## Verona series

- live sound
- installation
- audio visual
- broadcast



Klark Teknik Group, Walter Nash Road, Kidderminster, Worcestershire, DY11 7HJ. England.  
Tel: +44 1562 741515 Fax: +44 1562 745371  
email: sales@ktgplc.com www.midasconsoles.com





Midas XL4 and Paul 'PAB' Boothroyd  
(FOH Engineer for Sir Paul McCartney)



Midas XL4 and Daniel Green  
(FOH Engineer for Coldplay)



Midas XL4 and Robbie McGrath  
(FOH Engineer for The Rolling Stones)

## Midas - A Brief History

Since 1969 Midas has been the premier console brand throughout the world of professional audio. Midas consoles have been on the road with acts like Pink Floyd, Paul McCartney, Rolling Stones, Madonna, U2, Coldplay and Kylie just to name a few. From the famous Pro Series, the benchmark XL3 and XL4, and onto the current industry standard Heritage 3000, Midas remains the first choice for the most discerning of professional live sound engineers and has set the standard in the industry.

"The Midas sound" is a commonly heard phrase in the world of pro audio and refers to the sonic performance of Midas consoles - the mark by which others are judged. It comes simply from a unique combination of a superb dynamic range, very low noise floor, flawless audio path transparency and a beautifully warm EQ and the industries finest microphone pre-amp - plus thirty years of experience from a design team that not only understands audio but also loves music.

Sonic performance is only part of the reason behind Midas' success; there is also the outstanding product reliability. Midas consoles are able to handle thousands of gruelling events and hundreds of thousands of miles of punishing touring without major fault. To back up our impeccably solid construction and proven road-worthiness there is a three year global warranty, so our support network of dealers and distributors are on call at all times should any of our products need any kind of after-sales service.

Midas' proven technology and track record has made it an essential tool in numerous applications. Countless theatres, broadcasting suites, Houses of Worship, conference specialists and installation companies entrust their live sound requirements to Midas. The reason for this confidence is simple. It is founded on the fundamental philosophy behind Midas: totally uncompromising research, design, engineering and manufacturing which results in a product synonymous with excellence.

## Verona - A Step Above The Ordinary

Verona is, quite simply, the desk the industry has been asking Midas for. It takes the concept of the ultra-compact Venice, Midas' best selling console of all time, and elevates it to the next level. Verona delivers more inputs, more features, along with legendary Midas quality in a package that revolutionises the 8-buss market. Visually, the console looks stunning; despite it's physically modest proportions, it feels like a full-sized Midas to work on; and of course, most importantly of all, it sounds as good as it looks.

So what exactly is Verona?

Firstly, it's a truly professional desk aimed squarely at the professional market. Mechanically and electronically Verona is much more than just another 8-buss console. If you are primarily motivated by audio quality, rigid mechanical construction, long-term reliability and high residual values, then it is THE 8-buss console.

The Verona series consists of 6 models ranging from 24 up to a massive 64 inputs, and incorporates all the features and components that make it look, sound and feel like a true Midas. It has been designed from the ground up by the same team responsible for the XL4 and the Heritage Series consoles, including the industry-standard Heritage 3000.

Anyone who has ever bought a Venice and loved it is going to be captivated by the Verona - you get more inputs, more features and that all-important Midas quality. Available as an install or touring package the Verona will handle anything from houses of worship to broadcast / recording, theatre to corporate applications, and of course concert sound.

## Module Reference

This page is to be used in conjunction with the rest of the brochure as a reference and you may find it helpful to leave it folded out.

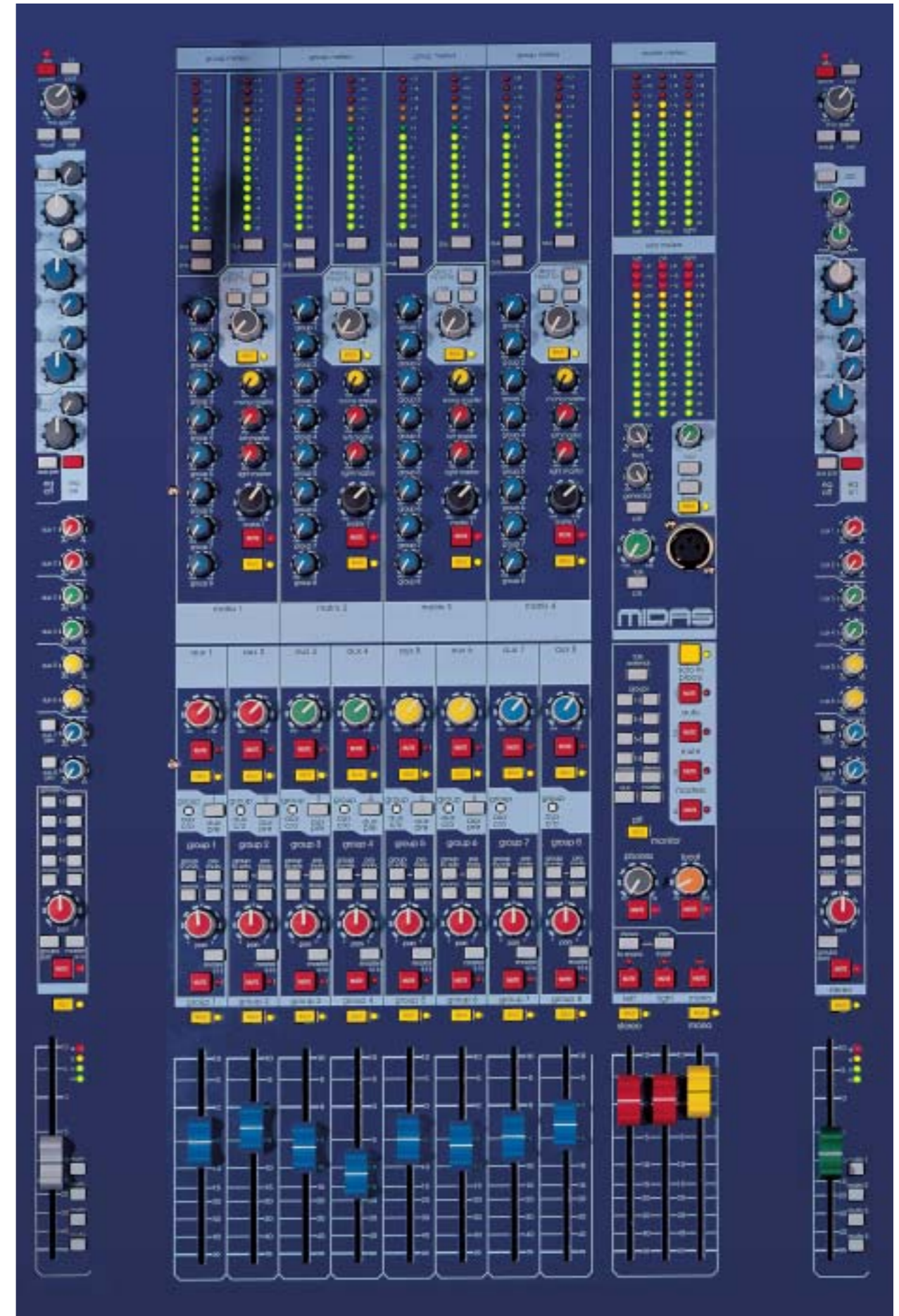



## Verona Key Features

### Superior Midas Sound

As with all our consoles we are continually striving to improve our sonic circuits. Verona uses a brand new premium performance mic amp design, with very high CMR performance providing simple, noise free interconnections.

High performance audio summing busses are used throughout and all main outputs are fully balanced with high current capability for noise free interconnections.

### Simple, Intuitive, Effective

Standing-up or sitting down? Either way – relax! Your driving a MIDAS, the controls feel right and it's an absolute pleasure. Whether it's the highly accurate 4-band EQ, the superb 100mm monorail faders or the simple layout, Verona is designed to make the live sound engineer feel at home. Mix the show of your life with confidence!

### Six Models - Verona 240 to Verona 640

Verona frames range from 24 inputs, and increment in blocks, of 8 up to a maximum of 64!

### Two Functions, One Desk

Easy set-up for FOH or monitors: the Group/Aux changeover switch, allow the choice of any combination of the aux outputs to be controlled via a 100mm fader including insert point. This flexibility is supported by the front panel Aux EQ defeat switch - when pressed any auxes assigned pre fader will be sent pre EQ.

### EQ

Highly accurate and musical swept 4-band EQ on every mono channel. The stereo channel is the same variety with swept mids. There is a switched high pass filter on every channel plus swept frequency on mono inputs.

### Channel Inserts

Front panel switchable insert points on each mic input.

### 8 Audio Sub Groups

Assigned from individual routing buttons (pre/post pan) from the input channel.

### 8 Aux Outputs

2 Aux busses with individual Pre/Post Fader switches and 6 Aux busses with global master Pre/Post fader assign.

### Spatial Image System™ (S.I.S.™)

Spatial Image System utilises a central cluster with a left-right system to form three discrete channels. Available from channels and groups.

### 12 x 4 Matrix

Fed from the Groups (or Auxes dependant on c/o switch), LR & C and external input on rotary controls. The external input can be individually routed directly to LR & C if required.

### 4 Mute Groups

Easy to programme, easy to re-call mutes created from inputs. The soft mute circuit has silent operation and LED indication.

### Multi Function Modules

Verona includes 8 multi function inputs as standard. These inputs can be mono mic, stereo line or both. The stereo line jacks are for use with either balanced or unbalanced line level signals and are protected from 48V phantom. The mono mic amp input incorporates a phase switch and a front panel switched insert.

### PSU's

The current sharing, voltage sensing, auto-switching PSU's are internally mounted. The "no hum" design saves the need for external racking and cabling. Verona 240 and 320 come with one internal PSU whilst Verona 400, 480, 560 and 640 come with two internal PSU's. Each frame includes an external connection port for an optional external PSU.

# Live Music: Touring And Install

The benefits of a Midas console are well known in the world of live music production. Performance, reliability, and audio quality, the Verona represents all the classic values of the brand, with the added advantages of smaller footprint, lighter frame, and true multi-functionality. These features, when combined with the audio quality of the Verona, ensure it will sit comfortably alongside its larger brothers.

The facing page highlights features which are most relevant to this application.



## VERONA FEATURE SET

### PREMIUM QUALITY PREAMP

#### DIRECT OUTPUTS

#### SWITCHABLE INSERT POINTS

#### SWEPT HPF (MONO INPUT ONLY)

#### MIDAS 4-BAND SWEPT EQ

#### PREFADE AUX EQ BYPASS

#### 8 AUX SENDS/OUTPUTS

#### GROUP ROUTING

#### SPATIAL IMAGING SYSTEM

#### SELF-CLEANING 100mm MONORAIL FADER

#### 4 "SOFT-CIRCUIT" MUTE GROUPS

#### 12x4 MATRIX

#### DIRECT INPUTS

#### GROUP/AUX CHANGEOVER

#### EXTREMELY LOW NOISE

#### REDUNDANT PSU CAPABILITY

#### ERGONOMIC LAYOUT

#### TALKBACK BUSS

#### STEREO SOLO BUSS WITH SOLO-IN-PLACE

#### LEFT, RIGHT & MONO MASTER OUTPUTS

#### CLEAR, COMPREHENSIVE METERING

#### 8 MULTI-FUNCTION INPUTS

## LIVE APPLICATION BENEFITS

**Premium Quality Preamp** - The Verona mic amps can handle input levels up to +21dB. The high CMR means the Verona performs excellently with long multicore runs and passive mic splits.

**Switchable Inset Points** - Invaluable for hurried set-ups. Doubles as a direct output on multi-function channels.

**Midas 4-Band Swept EQ** - Verona EQ has been designed to give the same legendary power, response and "feel" as the world-renown XL and Heritage series consoles.

**8 Aux Sends** - Six of the 8 Aux sends are globally switchable pre/post fade on a buss-by-buss basis. Auxes 7 & 8 are individually switchable pre/post fade. This format combines maximum flexibility with minimum set-up time. Use prefade with buss changeover\* for foldback sends.

**Self - Cleaning 100mm Monorail Faders** - Highly accurate and beautifully weighted.

**Redundant PSU Capability** - Every Verona console has backup PSU capability. Verona 400, 480, 560 and 640 models have redundancy as standard. Internal PSU's are auto-voltage sensing, current-sharing and auto-changeover.

**Left, Right & Mono Master Outputs** - Use the mono as a L&R sum, or discrete buss for driving centre cluster or Subs.

**8 multi-function inputs** - Multi-function channels can be mono mic, stereo line, or BOTH. Use for pre-show music, FX returns, stereo line inputs, or, using the insert send as a direct output, mono input and stereo effect simultaneously on ONE FADER.

## MONITOR APPLICATION BENEFITS

**8 Aux Outputs** - Aux Outputs feature the same high-quality output drivers as used on the master outputs, and deliver up to +21dB. Never run out of "drive".

**Group/Aux changeover\*** - The "Buss changeover" function not only switches the Aux buss to the Group fader and insert point, but also routes the Aux to the Matrix, and the Master outputs, allowing the engineer to create more mixes.

**4 "Soft-Circuit" Mute Groups** - Quick, silent muting/unmuting of multiple inputs.

**Clear And Comprehensive Metering** - 16-segment output meters that can be individually switched to show Aux levels instead of group or Matrix busses and four segment LED input meters on all input channels.

# Installation: Theatre And House Of Worship

Theatre and Houses of Worship present a unique set of challenges to the engineer, requiring that amplified sound be transparent, intelligible, and without extraneous noise. The Verona excels in all these important criteria, and its compact frame means minimum space is required in control room or auditorium. Features such as Stereo Imaging System, individual routing to groups, flexible Matrix, and a clear ergonomic control surface, make the Verona an obvious choice for front-of-any-house.

The facing page highlights features which are most relevant to this application.



## VERONA FEATURE SET

**PREMIUM QUALITY PREAMP  
DIRECT OUTPUTS**

**SWITCHABLE INSERT POINTS**

**SWEPT HPF (MONO INPUT ONLY)**

**MIDAS 4-BAND SWEPT EQ**

**PREFADE AUX EQ BYPASS**

**8 AUX SENDS/OUTPUTS**

**GROUP ROUTING**

**SPATIAL IMAGING SYSTEM**

**SELF-CLEANING 100mm MONORAIL FADER**

**4 "SOFT-CIRCUIT" MUTE GROUPS**

**12x4 MATRIX**

**DIRECT INPUTS**

**GROUP/AUX CHANGEOVER**

**EXTREMELY LOW NOISE**

**REDUNDANT PSU CAPABILITY**

**ERGONOMIC LAYOUT**

**TALKBACK BUSS**

**STEREO SOLO BUSS WITH SOLO-IN-PLACE**

**LEFT, RIGHT & MONO MASTER OUTPUTS**

**CLEAR, COMPREHENSIVE METERING**

**8 MULTI-FUNCTION INPUTS**

## INSTALLATION APPLICATION BENEFITS

**Premium Quality Preamp** - High-stability, low-noise mic amps allow the engineer to squeeze the last available dB out of difficult lavaliers & lectern mics.

**Direct outputs** - On every Mono channel. Use for driving dedicated FX processor, multitrack recording, paralleling inputs, etc. Direct outputs are post EQ as standard and can be set pre EQ via an internal jumper.

**Midas 4-Band Swept EQ** - Precise, powerful control of input frequency response. **Swept HPF** (mono input only) for exceptional control of unwanted low-frequency content.

**Prefade Aux EQ Bypass** - mixes can be independent of input EQ (Auxes 1-6). Use for recording, foldback, etc. in conjunction with group/aux changeover\*.

**Group Routing** - Subgroups can be used independently of the main outputs and the PAN control.

**Spatial Imaging System™** - The use of a S.I.S™ makes it possible for regional theatres to achieve results approaching the quality of Broadway productions. For Houses of Worship it provides excellent voice reproduction and the ability to handle all the musical requirements.

**4 "Soft-Circuit" Mute Groups** - Quick, silent muting/unmuting of multiple inputs.

**12x4 Matrix** - Create different mixes for balcony, front rows, show relay, foyer, recording, etc. Each subgroup has an assign to matrix switch, and can be pre or post fade. Each Matrix output features a **direct input**, with level control, which can be routed to matrix, stereo, and mono busses, and can be used as an additional input for house announcements, paging, etc.

**Group/Aux changeover\*** - The Group/Aux changeover function not only switches the Aux. buss to the Group fader and insert point, but also routes the Aux to the Matrix, allowing the engineer to create a matrix mix of combined subgroup and aux busses.

**Extremely Low Noise** - The Verona is QUIET, no unwanted noise during your show.

**Redundant PSU Capability** - Every Verona console has backup PSU capability. Verona 400, 480, 560 and 640 models have redundancy as standard. Internal PSU's are auto-voltage sensing, current-sharing and auto-changeover.

**Ergonomic Layout** - The control surface is clearly laid out, uncluttered, and intuitive. The console is easy to operate, even for a novice engineer.

**Talkback Buss** - Use to connect stage manager's talkback to console.

**Solo buss** - Stereo solo buss with separate mute and level control for headphone and local speaker outputs.

**8 multi-function inputs** - Multi-function channels can be mono mic, stereo line, or BOTH. Use for playback, FX returns, stereo, mono, or dual mono line inputs, in conjunction with WIDTH control.



# Corporate: Conference, AV and Broadcast

The corporate audio industry requires a console which is capable of handling the rapidly changing demands of contemporary events. The Verona brings all the large console experience at Midas to the compact console. Verona makes for quick, easy setups, simple operation, and professional results. All with Midas quality and reliability built-in.

The facing page highlights features which are most relevant to this application.



## VERONA FEATURE SET

### PREMIUM QUALITY PREAMP

#### DIRECT OUTPUTS

#### SWITCHABLE INSERT POINTS

#### SWEPT HPF (MONO INPUT ONLY)

#### MIDAS 4-BAND SWEPT EQ

#### PREFADE AUX EQ BYPASS

#### 8 AUX SENDS/OUTPUTS

#### GROUP ROUTING

#### SPATIAL IMAGING SYSTEM

#### SELF-CLEANING 100mm MONORAIL FADER

#### 4 "SOFT-CIRCUIT" MUTE GROUPS

#### 12x4 MATRIX

#### DIRECT INPUTS

#### GROUP/AUX CHANGEOVER

#### EXTREMELY LOW NOISE

#### REDUNDANT PSU CAPABILITY

#### ERGONOMIC LAYOUT

#### TALKBACK BUSS

#### STEREO SOLO BUSS WITH SOLO-IN-PLACE

#### LEFT, RIGHT & MONO MASTER OUTPUTS

#### CLEAR, COMPREHENSIVE METERING

#### 8 MULTI-FUNCTION INPUTS

## CORPORATE APPLICATION BENEFITS

**Premium Quality Preamp** - High-stability, low-noise mic. amps allow the engineer to squeeze the last available dB out of difficult lavaliers & lectern mics.

**Midas 4-Band Swept EQ** - Precise, powerful control of input frequency response. **Swept HPF** (mono input only) for exceptional speech intelligibility. Swept mids on dual-purpose inputs improves the quality of even the worst intro cassette tape.

**Self - Cleaning 100mm Monorail Faders** - Highly accurate and beautifully weighted.

**Spatial Imaging System™** - Mix in true 3-channel audio, centre speaker for speech, stereo system for music and sound effects.

**4 "Soft-Circuit" Mute Groups** - Quick, silent muting/unmuting of multiple inputs.

**12x4 Matrix** - Create different mixes for delays, front rows, recording, etc. Each group has an assign to matrix switch, and can be pre or post fader. Each Matrix output features a **direct input**, which can be routed to matrix, stereo, and mono busses. Matrix Outputs feature the same high-quality output drivers as used on the master outputs, and can deliver up to +21dB. Never run out of "drive".

**Group/Aux changeover\*** - The Group/Aux changeover function not only switches the Aux buss to the Group fader and insert point, but also routes the Aux to the Matrix, allowing the engineer to create a matrix mix of combined subgroup and aux busses.

**Extremely Low Noise** - The Verona is QUIET, minimising distracting noise during sensitive conferences.

**Redundant PSU Capability** - Every Verona console has backup PSU capability. Verona 400, 480, 560 and 640 models have redundancy as standard. Internal PSU's are auto-voltage sensing, current-sharing and auto-changeover.

**Ergonomic Layout** - The control surface is clearly laid out, uncluttered, and intuitive. The console is easy to operate, even for a novice engineer.

**8 multi-function inputs** - Multi-function channels can be mono mic, stereo line, or BOTH. Use for playback (CD, MD, DAT, Cassette, PC Audio), FX returns, stereo or dual mono line inputs, in conjunction with WIDTH control.

**Clear And Comprehensive Metering** - 16-segment output meters that can be individually switched to show Aux levels instead of group or Matrix busses and four segment LED input meters on all input channels.

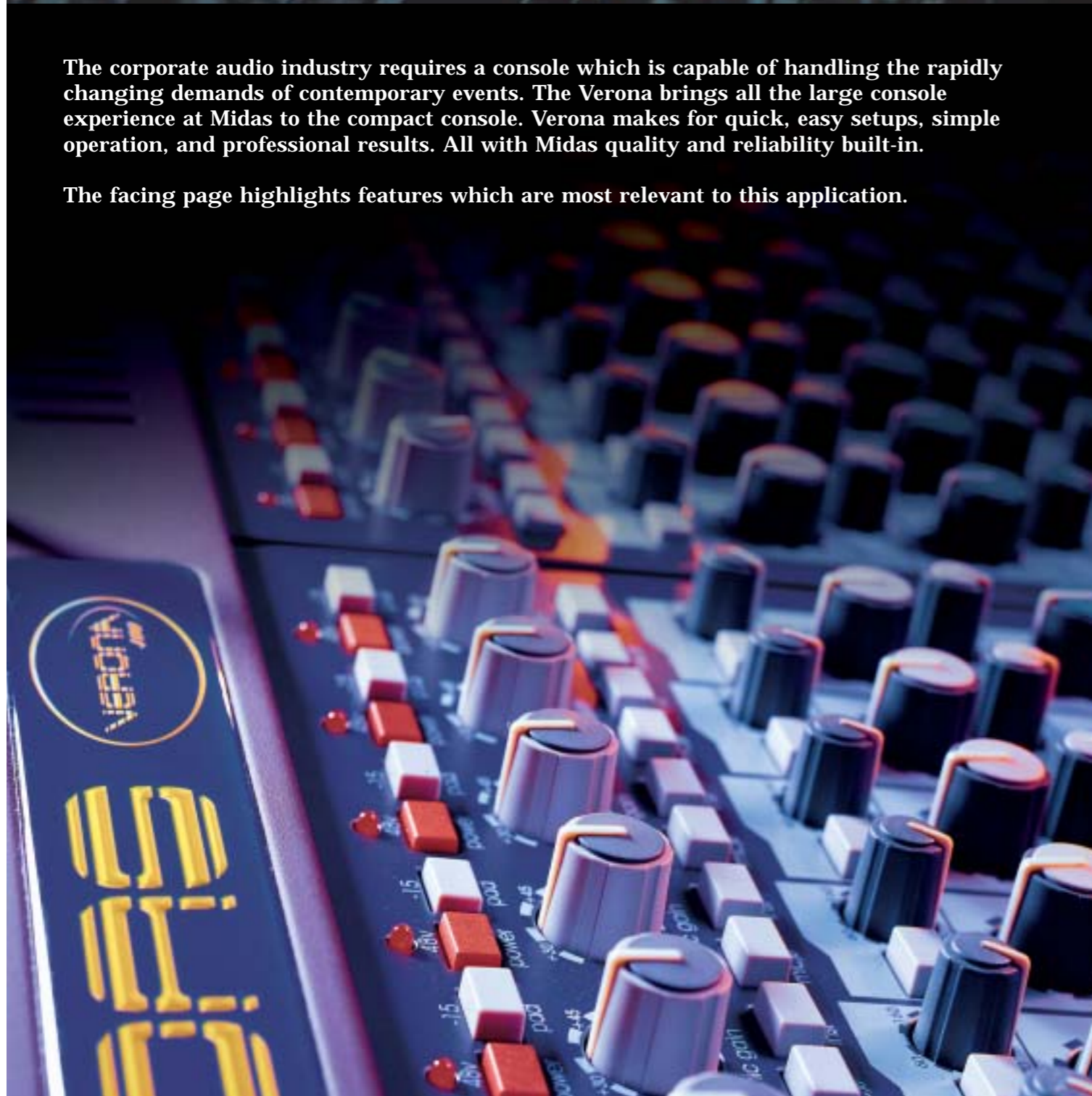

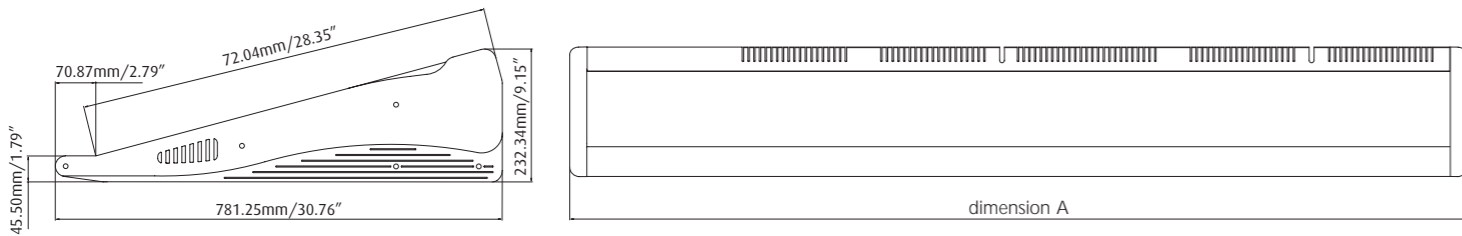

## Weights And Dimensions

Verona 240 24 mic inputs	dimension A	1085.00mm/42.72"	weight* 45kg/99.23lbs
Verona 320 32 mic inputs	dimension A	1327.00mm/52.24"	weight* 55kg/121.25lbs
Verona 400 40 mic inputs	dimension A	1569.00mm/61.78"	weight* 65kg/143.30lbs
Verona 480 48 mic inputs	dimension A	1811.00mm/71.30"	weight* 75kg/165.34lbs
Verona 560 56 mic inputs	dimension A	2053.00mm/80.83"	weight* 85kg/187.39lbs
Verona 640 64 mic inputs	dimension A	2295.00mm/90.35"	weight* 95kg/209.44lbs

\* estimated weight out of flight case

## Verona Overview

### Unique Module Construction

Semi modular construction in 8 channel blocks.

Modules blocks feature a structural sub chassis carrying 2 PCBs and a separate (non structural) dress facia.

This construction eliminates the need for long ribbon cables or expensive back planes and improves both reliability and crosstalk without sacrificing serviceability.

The sub chassis provides electrical screening under the pcbs protecting busses from noise pickup and allowing the use of internal power supplies without interference.

PCBs are produced with all surface mount components on the underside so that they are not affected by the build up of debris after years of use.

Electrolytic capacitors are mounted conventionally on the top of the board which provides them with a high degree of thermal protection increasing reliability and life time.

The non structural front panel can be easily removed allowing direct access to the pcbs for service. All major circuit nodes are marked as test points on the top of the board to simplify fault diagnosis at system level or down to component level in situ.

### Mono Inputs Module

A brand new premium performance, mic amp design with very high CMR performance providing simple, noise free interconnections.

Mic phase change over switch on every channel.

Switched high pass filter on every channel plus swept frequency on mono inputs.

Switched insert points on every channel.

4 LED input metering on every channel.

Highly accurate and musical swept 4 band EQ on every mono channel.

Soft mute circuit with silent operation and led indication.

AUX EQ defeat switch.

100mm monorail faders.

### Mono Input Connectors

The Main XLR input is for use with balanced Mic or Line level signals.

The Line Jack is for use with balanced or unbalanced line level signals and is protected from 48V phantom.

The Insert Jack is normalised and unbalanced with the send on the tip and the return on the ring. The insert position is pre EQ.

The Direct Output Jack is impedance balanced with hot on the tip and cold on the ring. The signal is post EQ but pre mute and fader.

### Multi Function Module

Each frame size is loaded with one multi function input module containing 8 multi function input channels as standard.

Each multi function input channel has 4 band EQ (with swept mids) and can be used as a stereo line and/or a mono mic.

The mono mic amp input incorporates a phase switch and a front panel switched insert.

### Multi Function Input Connectors

The Main XLR input is for use with balanced Mic (or line) level signals.

The Line Jacks are for use with stereo balanced or unbalanced line level signals and are protected from 48V phantom.

The Insert Jack is normalised and unbalanced with the send on the tip and the return on the ring. The insert position is pre EQ acting on the mic input only.

### Output Module

High performance audio summing busses are used throughout.

2 Aux busses with individual Pre/Post Fader switches.

6 Aux busses with global master Pre/Post Fader assign.

Front pan (per channel) switch for Pre/Post EQ selection for any of the 6 "global" auxes that are set in pre fader mode.

8 individually assigned Group busses with optional pan.

Stereo and Mono Master busses with optional LCR panning (SIST™).

4 Auto mute busses individually selectable to act on any input channel as required.

All main outputs are fully balanced with high current capability for noise free interconnections.

14 Output LED bar graphs with 16 segments.

Fader change over for Aux and Group outputs (for monitor applications).

12 input, 4 output Matrix section.

Comprehensive PFL and stereo AFL solo system including solo in place.

### Output Section Connectors

The Group XLR output provides a balanced, 50R source, line level signal.

The Group Insert Jack is normalised and unbalanced with the send on the tip and the return on the ring.

The Matrix XLR output provides a balanced, 50R source, line level signal.

The Aux Send XLR output provides a balanced, 50R source, line level signal.

The Direct Input Jack is for use with balanced or unbalanced line level signals.

The Stereo Master XLR outputs provide a balanced, 50R source, line level signal.

The Stereo Master Insert Jacks are normalised and unbalanced with the send on the tip and the return on the ring.

The Mono Master XLR outputs provide a balanced, 50R source, line level signal.

The Mono Master Insert Jack is normalised and unbalanced with the send on the tip and the return on the ring.

The Tape Phono inputs and outputs are unbalanced and can operate at a nominal 10dB below line level if required.

The Local XLR outputs provide a balanced, 50R source, line level signal.

The Talk input and output XLRs are balanced line level signals.

The Talk XLR input is for use with balanced Mic level signals.

# MONO INPUT

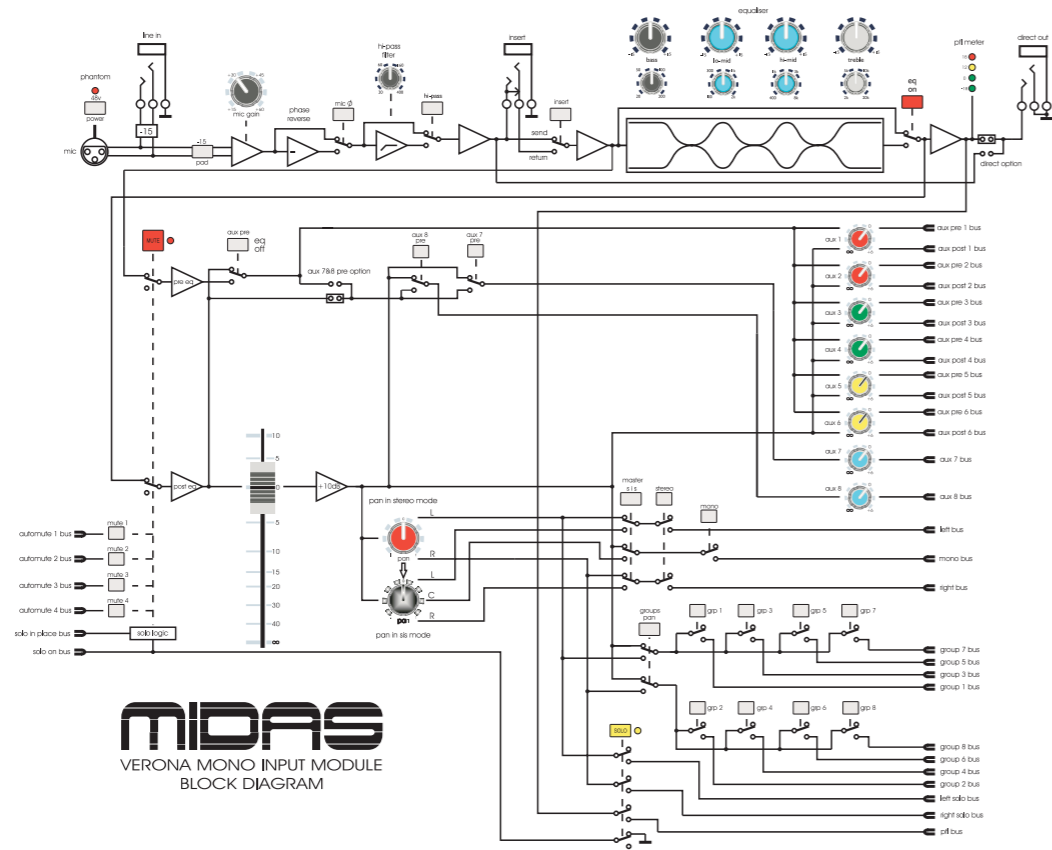

# GROUP/MATRIX

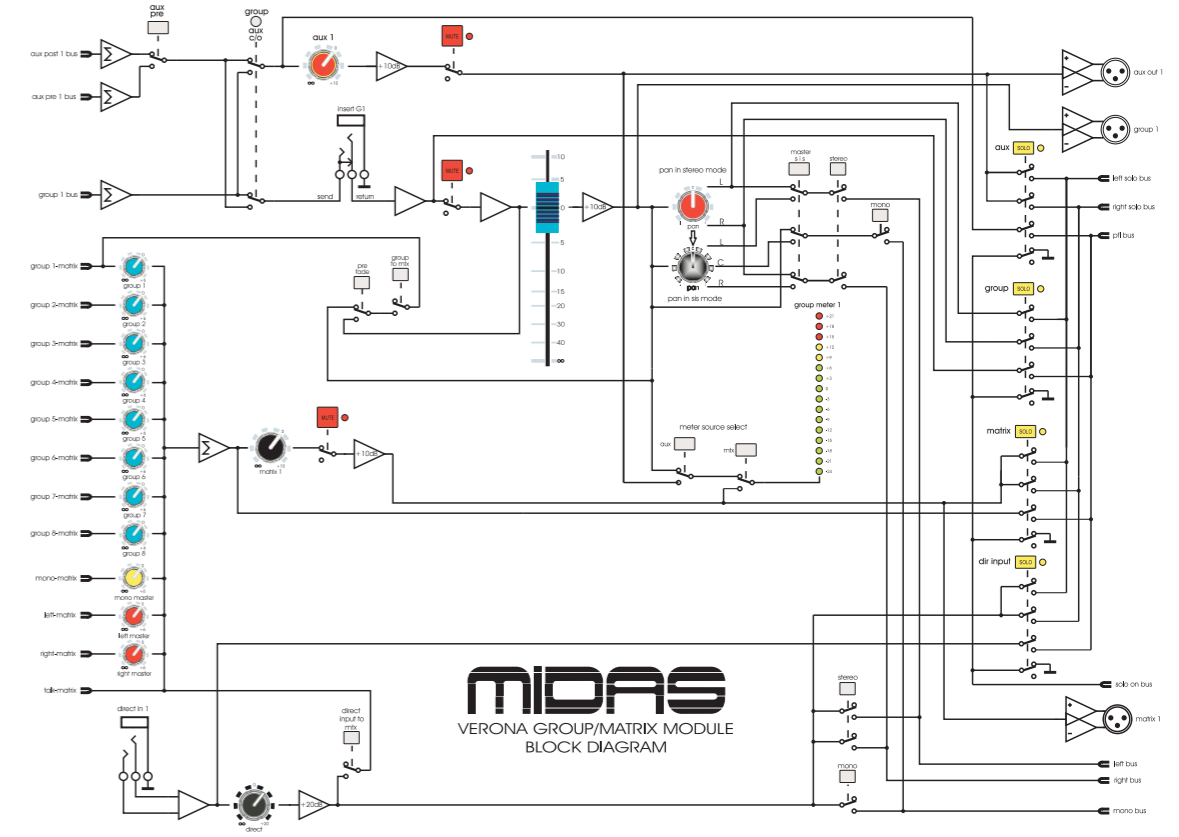

# MULTI FUNCTION INPUT

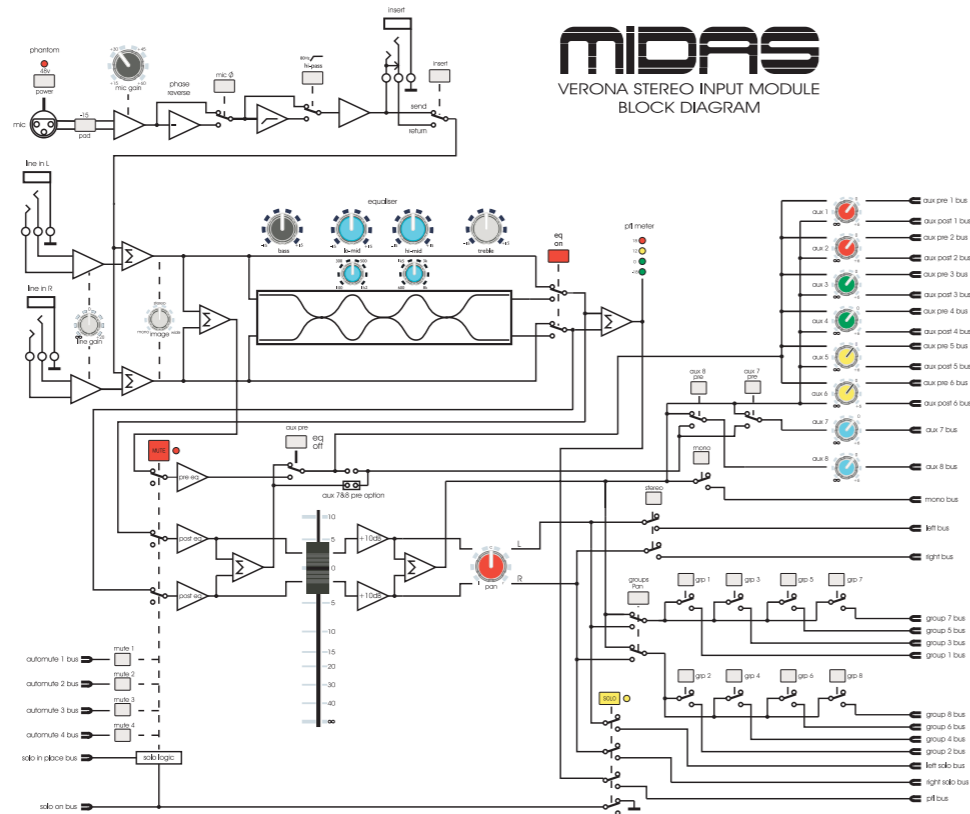

# MASTER

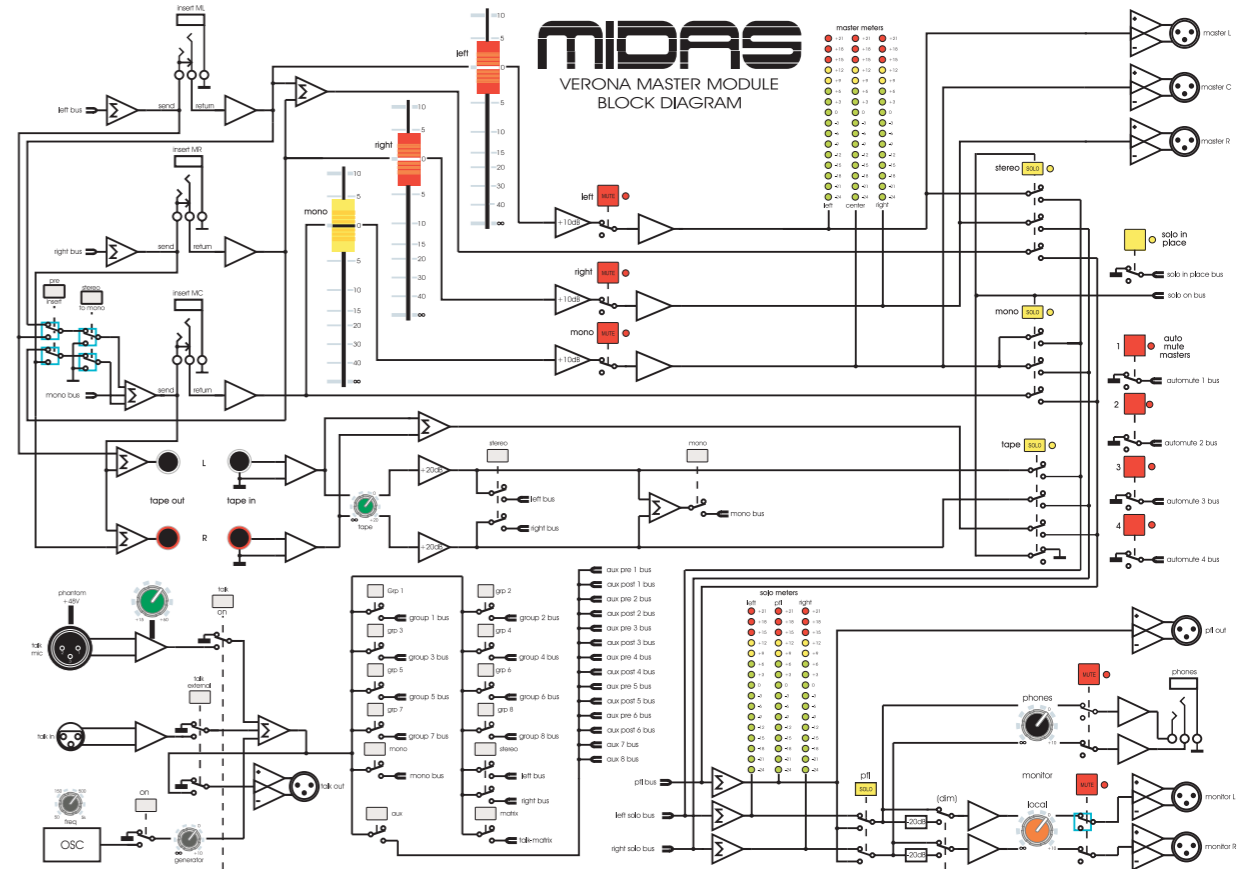



## Verona: Power Supply

The Midas V190 is a linear type, 19" rack mounted power supply, which is designed to provide dual psu redundancy for 24, 32 and 64 channel Verona consoles and also as an additional external psu option for the entire Verona Range.

The front panel features a large illuminated power switch, individual LED indicators for rail status, and a "low mains" warning LED. The V190 has parallel outputs on both front and rear, to allow for convenient connection to the console and multiple psu linking. For multiple psu applications, no additional switching unit is required.



## Verona: Spatial Image System™

The benefits of S.I.S.™ can only be realised with a console that is built for the task. Conventional consoles can be used for three channel mixing, but the methods for doing so are complicated and unorthodox, forcing the engineer to work in unaccustomed ways, limiting creative flexibility, making use by visiting operators impractical.

When using Midas S.I.S.™ capable mixing consoles the pan controls may be switched for either conventional or S.I.S.™ operation on each input channel. In S.I.S.™ mode the centre position of the control routes the input to a separate channel output, in this case it pans from left to centre or right to centre. Back up vocalists can be panned slightly into the centre cluster to improve intelligibility while keeping the featured vocal 'front and centre'. Musical instruments can be placed in a conventional mix then easily switched to the centre for solos. In theatrical productions S.I.S.™ gives the ability to pan an actor's voice across three channels following their on stage movements. In stereo only productions the centre output can be used to provide a mono to sub base feed activating a single 'L + R to Centre' switch.

## Verona Statistics

The Verona is a 22 buss console with an additional 12 X 4 output matrix. The busses are as follows:-

8 groups	=	8
8 aux	=	8
1 stereo master	=	2
1 mono master	=	1
1 stereo AFL	=	2
1 mono PFL	=	1
TOTAL	=	22

The Verona has 4 automute sub groups and a Solo In Place mute group.

The Verona 480 has 48 mic input channels plus an additional 16 (8 stereo) line inputs and 4 direct inputs on the master module.

The Verona 480 has a total XLR input count of 50 as follows:-

48 channel mic inputs  
1 talk external input  
1 talk line input

The Verona 480 has a total XLR output count of 27 as follows:-

8 audio group outputs  
8 aux bus outputs  
4 matrix outputs  
3 master outputs  
3 solo outputs  
1 talk external output

The Verona 480 has a total of 60 1/4 inch balanced input jacks as follows:-

56 channel line inputs  
4 matrix direct inputs

The Verona 480 has a total of 63 1/4 inch (send and return) jacks for inserts as follows:-

48 input channel inserts  
8 audio group inserts  
4 matrix inserts  
3 master inserts

The Verona 480 has a total of 40 1/4 inch impedance matched output jacks as follows:-

40 input channel direct outputs

The Verona 480 has a total of 4 RCA phono connections as follows:-

2 tape inputs  
2 tape outputs

The Verona 480 has 59 long throw faders for mix control.

The Verona 480 has a total of 62 peak program meters with 16 LED segments on all 14 output meters and 4 LED segments on input channels.

## Verona Performance Specifications

Input Impedance	Mic Line	1K5 Balanced 10K Balanced
Input Gain (all faders at 0dB)	Mic Mic + Pad Mono Channel Line Inputs	Continuously variable from +15dB to + 60dB Continuously variable from 0dB to + 45dB
	Stereo Channel Line Inputs Direct Inputs	Continuously variable from 0dB to + 45dB (-15dB to +30dB with pad)
		Continuously variable from + 20dB to off Continuously variable from + 20dB to off
Maximum Input Level	Mic Mic + Pad Mono Channel Line Stereo Channel Line	+ 6dBu + 21dBu + 36dBu + 26dBu
CMR at 100Hz	Mic (gain + 40dB) Mic + Pad (gain 0dB) Line (gain 0dB)	Typ 95dB Typ 80dB Typ 80dB
CMR at 1KHz	Mic (gain + 40dB) Mic + Pad (gain 0dB) Line (gain 0dB)	Typ 95dB Typ 80dB Typ 80dB
Frequency Response (20 to 20KHz)	Mic to Mix (gain + 40dB)	+ 0dB to - 1dB
Noise (20 to 20KHz)	Mic EIN ref. 150 Ohms (gain + 60dB)	- 129dBu
System Noise (20 to 20KHz)	Summing Noise (48 channels routed with faders down)	- 80dB
	Line to Mix Noise (48 channels routed at 0dB, pan centre)	- 75dB
Distortion at 1KHz	Mic to Mix (+ 40dB gain, 0dBu output)	< 0.03%
Crosstalk at 1KHz	Channel to Channel Mix to Mix Channel to Mix Maximum Fader attenuation Maximum Mute attenuation	< - 90dB < - 90dB < - 90dB > 100dB > 100dB
Output Impedance	All Line Outputs Headphones	50 Ohms Balanced Source to drive > 600 Ohms To drive > 100 Ohms
Maximum Output Level	All Line Outputs Headphones	+ 21dBu + 21dBu
Nominal Signal Level	Mic Line Headphones	- 60dBu to 0dBu 0dBu + 10dBu
Equaliser	Hi pass slope Hi pass frequency Treble Gain	12dB / Oct. Continuously variable - 3dB point from 20Hz to 400Hz Continuously variable + 15dB to - 15dB Centre detent = 0dB
	Treble Freq. Hi Mid Gain	Continuously variable - 3dB point from 2K to 20K Continuously variable + 15dB to - 15dB Centre detent = 0dB
	Hi Mid Freq. Hi Mid Bandwidth Lo Mid Gain	Continuously variable centre from 400Hz to 8K 1 Oct. Continuously variable + 15dB to - 15dB Centre detent = 0dB
	Lo Mid Freq. Lo Mid Bandwidth Bass Gain	Continuously variable centre from 100Hz to 2K 1 Oct. Continuously variable + 15dB to - 15dB Centre detent = 0dB
	Bass Freq.	Continuously variable - 3dB point from 20Hz to 200Hz

\* Due to a policy of continual improvement Midas reserves the right to alter the specification and performance at any time without prior notification.